

FREEZER | Countertop Freezers

UPRIGHT FREEZER ▶ WITH CANOPY

RNG 90C

CUSTOMIZATION AVAILABLE
PERSONALIZZAZIONE DISPONIBILE



55 mm	L2 -18°C -12°C	C ENERGY CLASS	3 +25°C/60RH
LED	Key lock	Triple glass	GAS R290

DETAILS

Lock fitted as standard	Painted aluminium door frame with integrated handle	Upright freezer with advertisement canopy
-------------------------	---	---

GENERAL FEATURES

- 90 Lt. Upright freezer with advertisement canopy
- White coated steel for internal and external side
- Static Cooling
- Manual Defrost
- Foaming Agent Cyclopentane (55mm per side)
- Removable Gasket
- Interior LED light / LED light for canopy
- Triple heated safety tempered glass
- Self Closing Door
- Painted aluminium door frame with integrated handle
- Lock fitted as standard
- Adjustable shelves: 3 Pcs
- N.4 Adjustable feet
- Energy efficiency class: C

TECHNICAL SPECIFICATIONS

Capacity	116 L
Temperature	L2 (-12°C--18°C)
Consumption	3.41 kWh/24h
Rated Power	217 W
Noise level	45 dB(A)
Net Weight	54 Kg
Gross Weight	59 Kg
External Dimensions (WxDxH mm)	610x560x895
Internal Dimensions (WxDxH mm)	500x430x540
Packaging dimensions (WxDxH mm)	655x595x965
Loading quantities 20'/40'/40'HQ	54/114/114

PRODUCT DIMENSIONS

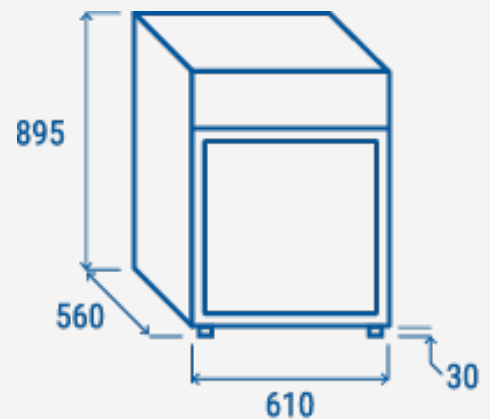

CERTIFICATION

CE RoHS

